

- Snap action contacts mechanism
- Positive opening NC Contact (→) (IEC 60947-5-1)
- For applications on security system
- Screw or quick connect (faston) terminals
- Increased contact gap
- In conformity with Low Voltage Directive 2006/95/EC
- IEC 60947-5-1 approved component

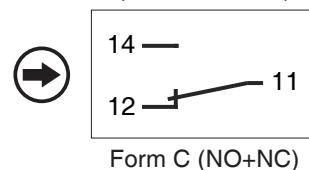

Circuitry
(IEC 60947-5-1)



Specifications

Utilization Category (IEC 60947-5-1)	AC-15
Rated Operational Voltage (Ue)	240V
Rated Operational Current (Ie)	3A
Rated Insulation Voltage (Ui)	300V
Conventional free air thermal current (Ith)	10A
Contact Resistance	50mΩ maximum initial (at 1A 5Vcc)
Ambient Temperature	+85°C maximum
Degree of Protection	IP20 (with assembled M33 terminal cover) (IEC 60529)
Operating Speed	0,5mm/s minimum until 1m/s maximum (at pin plunger)
Mechanical Life Expectancy	1.000.000 cycles at 90 cycles/min max.
Electrical Life Expectancy	10.000 cycles at 6 cycles/min max.
Materials	Enclosure: Polyester reinforced
	Pin Plunger: Polyamide reinforced
	Moving Blade: Copper Alloy
	Contacts: Silver alloy
	Actuators: Lever actuator: Lever: Stainless steel
	Plunger actuator: Actuator: Nickel plated brass

Subject to change without prior notice

Ordering Information

M K F F

Actuator	
Plunger	= F
Long Hinge Lever	= G
Short Hinge Lever	= H
Long Roller Hinge Lever	= J
Medium Roller Hinge Lever	= K
Short Roller Hinge Lever	= L

Terminal	
Screw	= null
Faston	= F

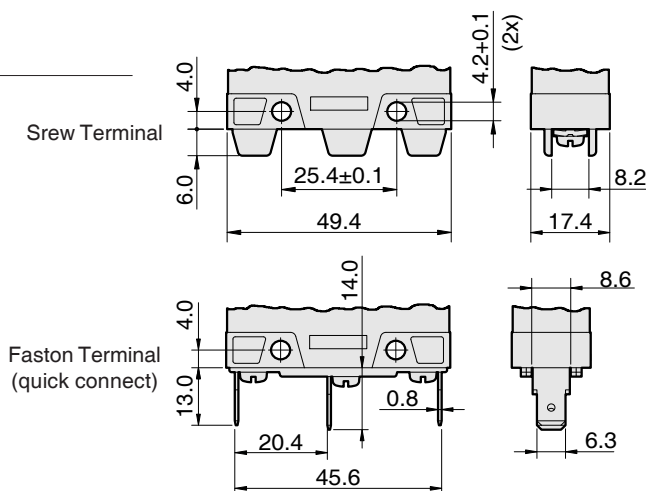

Actuators (dimensions in mm)

Plunger Actuator

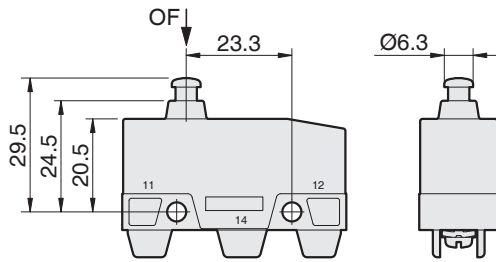

Code	Travel Diagram
MKF	
MKFF	

Hinge Lever Actuator

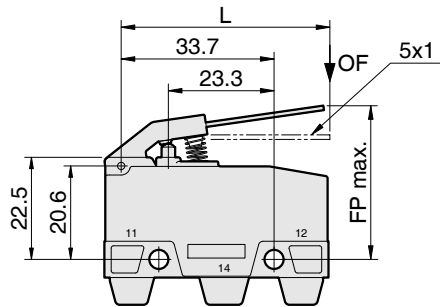

Code	L	FP max.	Travel Diagram
MKG	69,4	39,2	
MKGF			
MKH	46	35,2	
MKHF			

Roller Hinge Lever Actuator

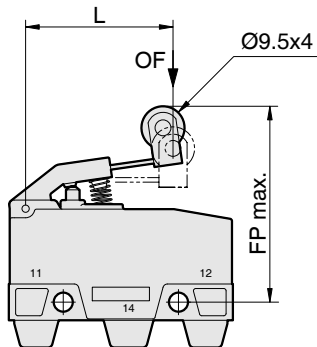

Code	L	FP max.	Travel Diagram
MKJ	66,4	50	
MKJF			
MKK	54,4	47,8	
MKKF			
MKL	32,5	44,2	
MKLF			

Positive Opening Operation on NC Contact

- OF is the necessary force to operate the product in normal use conditions.
- To ensure the positive opening, the external actuator element will provide a force PF on switch's actuator, greater than OF and in the same position.

Diagrams represents the operational contacts travels based on actuators position. Note that to ensure the positive opening, the actuator should be moved at least to the indicated travel (⊕).

Code	OF max. ① (kgf)	PF min. ② (kgf)	
MKF	MKFF	0,50	4,40
MKG	MKGF	0,10	0,65
MKH	MKHF	0,15	1,00
MKJ	MKJF	0,10	0,68
MKK	MKKF	0,13	0,86
MKL	MKLF	0,21	1,39

Accessory

M33 - Terminal cover (to be screw fixed in the bottom side of the base)

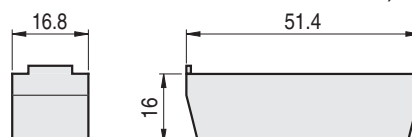

INSTALLATION INSTRUCTIONS

1- Positive Opening

- The symbol  (IEC 60947-5-1 Annex K) identifies a positive opening in the normally closed contact (NC).
- A switch has positive opening when all NC contact elements can be certainly led to open position. There is no elastic connection between the mobile contact and the actuator element where the force is applied.
- With the positive opening system, even with a internal malfunction of the switch, for example welding of contacts, the opening of the NC contact and "shutdown" of the circuit controlled by this switch is guaranteed, provided the "union" strength between the mobile contact and NC contact, does not exceed 10 N (according to item K8.3.7 of IEC 60947-5-1 standard).
- To ensure positive opening, the external actuator element will provide a force on the actuator's switch greater than the necessary force to operate the product in normal use conditions. This force will be applied in the same position of OP.
- The connections of security circuits should be made only in NC contact and the auxiliary connections in NO contact.

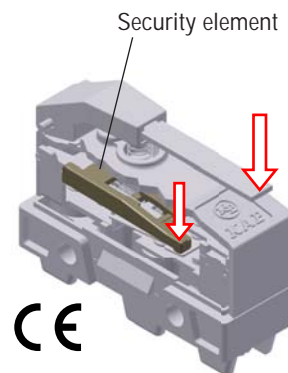

Switch operated and with the security element activated

2- Electrical Connections

2.1- Cable's cross section (flexible cables)

- minimum: 1 x 0,5 mm²
- maximum: 2 x 2,5 mm²
- Fixing torque: 0,3 until 0,7 Nm

2.2- Circuitry (with protection fuse)

- Circuit: IEC 60947-5-1 form C
- Marking: IEC 60947-1

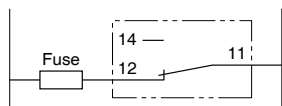

2.3- Switch MK with M33 terminal cover

- We recommend using M33 to protect people against access to dangerous parts.
- The M33 is fixed to MK by self-tapping screw.
- Fixing torque: 0,2 until 0,5 Nm
- Triple cables output options: the first one is indicated by screwdriver and the others by arrows (see figure below)
- To create the cable outline, use screw driver to break the membrane of the chosen output.

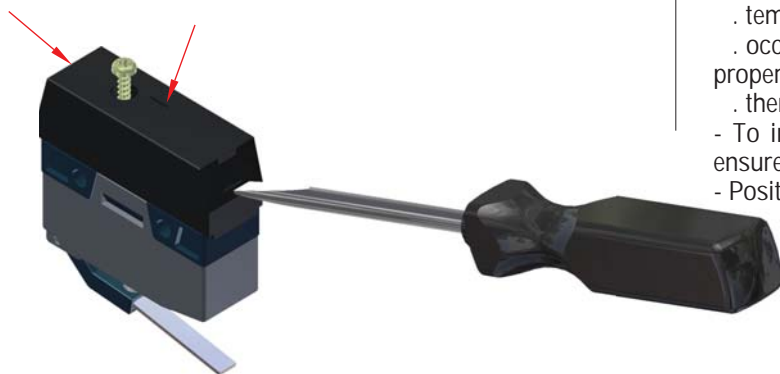

2.4- Cables Fixing

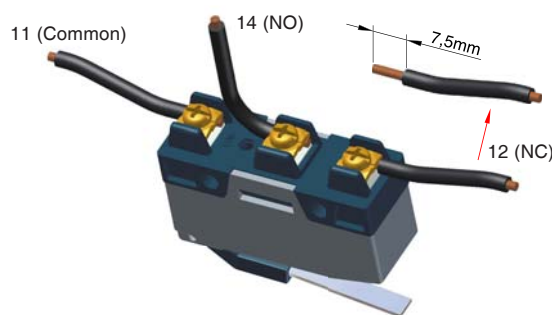

2.5- Short-circuit protective device

- 10A fuse type gG connected in series with the security circuit.

3- Housing Fixing

- Use M4 screws with flat washer.
- Fixing torque: 0,4 until 0,7Nm

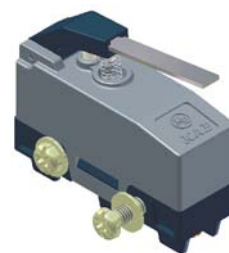

4- Additional Cares

- Avoid environments where:
 - . temperature changes cause condensation.
 - . occur excessive vibration and shock and may damage the proper functioning of the switch.
 - . there is explosive or flammable gas.
- To install the product, attempt to the specified limits to ensure a correct performance.
- Positive Opening  : attention to the values specified in the catalog to the necessary travel and force to ensure a perfect operation of positive opening system.
- Do not use these products as a mechanical stop.
- Do not use these products as safety or emergency stop devices or in any other application where the failure of the product could result in personal injury.

INSTALLATION INSTRUCTIONS - Continuation

⚠ WARNING

- Turn off the power to make electrical connections or before any maintenance on the switch or equipment where it is applied. **Electric shock will result in death or serious injury.**
- Installation and maintenance services for electrical equipment should be executed only by qualified personnel.
- Read these instructions carefully. Retain instructions for future reference.
- Inappropriate use of the product could result in personal injury and/or property.
- Additional informations: export@kap.com.br

5- Technical Data

- In conformity with standards	IEC 60947-5-1 / EN 60947-5-1/IEC 60647-1/ EN 60947-1/ IEC 60529/ EN 60529/ Directive 2006/95/EC
- Utilization Category	AC-15
- Rated Operational Voltage (Ue)	250 V
- Rated Operational Current (Ie)	3 A
- Rated Insulation Voltage (Ui)	300 V
- Conventional Free Air Thermal Current (Ith)	10 A
- Rated Frequency	50/60 Hz
- Contact Resistance	50 mΩ maximum initial (at 1 A, 5 Vdc)
- Rated Conditional Short-circuit Current	100 A
- Degree of Protection	IP20 (IEC 60529) with M33 terminal cover assembled Equipment Protection: without protection against ingress of water and protection against access to hazardous parts ingress of solid objects up to ø12,5mm People Protection: protection against accidental touch by persons fingers
- Ambient Temperature	+85°C maximum
- Mechanical Durability	1.000.000 cycles until 90 cycles/min max.
- Electrical Durability	10.000 cycles until 6 cycles/min max.
- Operating Speed	0,5 mm/s minimum until 1 m/s maximum (at pin plunger)
- Pollution Degree	2 (IEC 60947-1)
- Electromagnetic Compatibility (EMC)	not applicable (IEC 60947-1)
	- Immunity: equipment not incorporating electronic circuits
	- Emission: electromagnetic disturbances can only be generated by equipment during occasional switching operations and the duration of the disturbances is of the order of milliseconds
- Material Housing	Glass-reinforced polymer

6- Operation Recommendations

The correct way to operate the switch may affect significantly their durability. Check below some examples of actuators and their directions of operation.

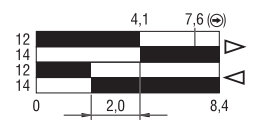
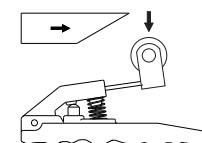
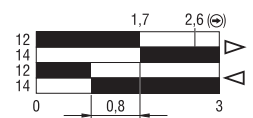
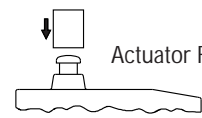
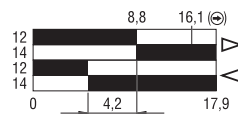
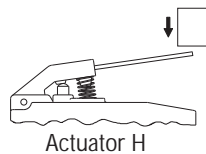

7- Travels

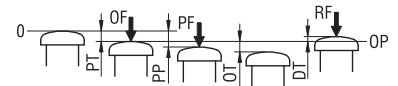
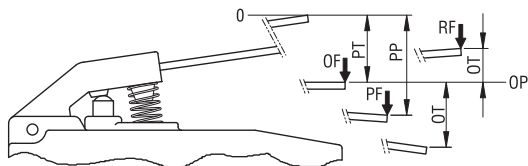

Terminology:

- OF..... Operation force
- PF..... Positive opening force
- RF.....Release force
- DT..... Differential travel
- PT..... Pre travel
- FP..... Free position
- OP..... Operating position
- PP.....Positive opening travel
- OT..... Overtravel

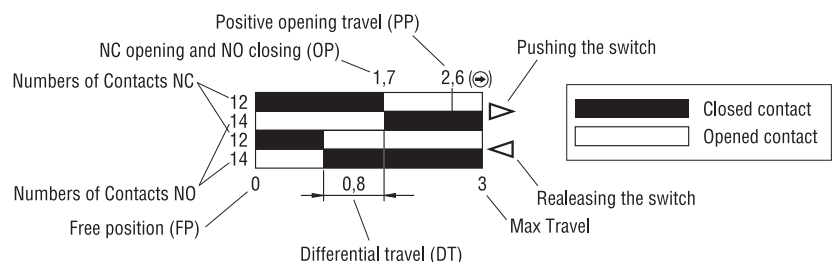

MK Series

Basic Switch 2NC with Positive Opening

- Slow action contacts mechanism
- 2 NC contacts with positive opening  (IEC 60947-5-1)
- For applications on security system
- Ideal for applications where redundancy is needed
- Glass-reinforced polyamide V-0 enclosure
- Increased contact gap
- Screw terminals
- In conformity with Low Voltage Directive 2006/95/EC

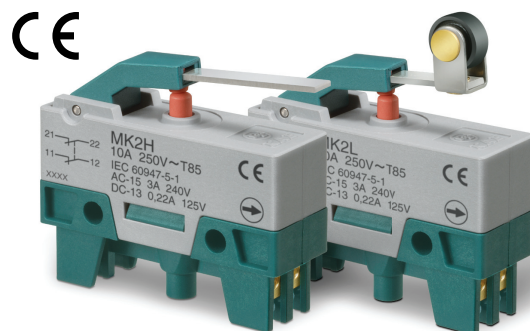

Circuitry
(IEC 60947-5-1)

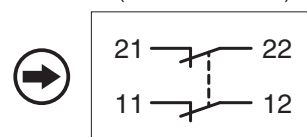

Form Y+Y

Specifications

Utilization Category (IEC 60947-5-1)	AC-15	DC-13	
Rated Operational Voltage (Ue)	240 V	125 V	
Rated Operational Current (Ie)	3 A	0,22 A	
Rated Insulation Voltage (Ui)	300 V		
Conventional Free Air Thermal Current (Ith)	10 A		
Rated Impulse Withstand Voltage (Uimp)	1500 V		
Contact Resistance	50 mΩ maximum initial (at 1A 5Vcc)		
Ambient Temperature	+85°C maximum		
Degree of Protection	IP20 (with assembled MK23 terminal cover) (IEC 60529)		
Operating Speed	8 mm/s minimum until 1 m/s maximum (at pin plunger)		
Mechanical Life Expectancy	1.000.000 cycles at 90 cycles/min max.		
Electrical Life Expectancy	10.000 cycles at 6 cycles/min max.		
Materials	Enclosure:	Polyamide reinforced	
	Pin Plunger:	Polyamide reinforced	
	Moving Blade:	Copper Alloy	
	Contacts:	Silver alloy	
	Actuators:	Lever actuator:	Lever: Stainless steel
			Roller: Polyamide reinforced
	Plunger actuator:	Actuator: Nickel plated brass	

Subject to change without prior notice

Ordering Information

M K 2 A

Actuator	
Pin Plunger	= A
Plunger	= F
Hinge Lever	= H
Roller Hinge Lever	= L

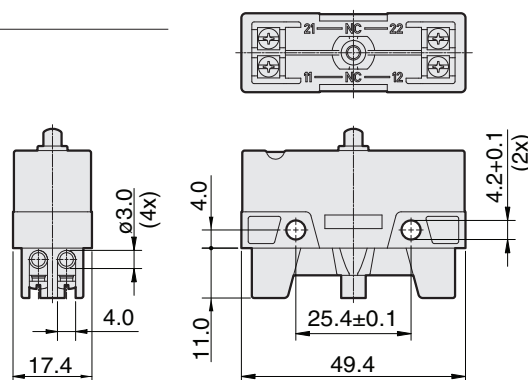

Actuators (dimensions in mm)

Pin Plunger Actuator

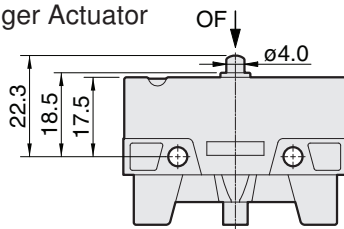

Code	Travel Diagram
MK2A	

Plunger Actuator

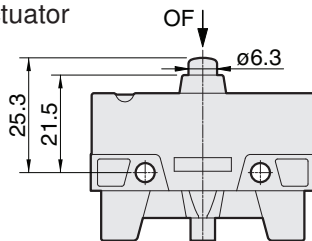

Code	Travel Diagram
MK2F	

Hinge Lever Actuator

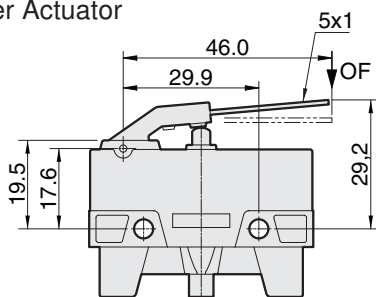

Code	Travel Diagram
MK2H	

Roller Hinge Lever Actuator

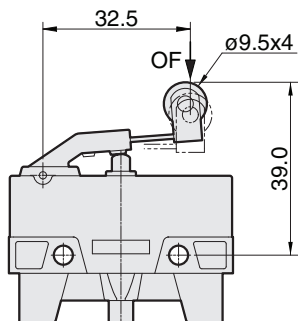

Code	Travel Diagram
MK2L	

Subject to change without prior notice

Positive Opening Operation on NC Contact

- ① OF is the necessary force to operate the product in normal use conditions.
- ② To ensure the positive opening, the external actuator element will provide a force PF on switch's actuator, greater than OF and in the same position.

Diagrams represents the operational contacts travels based on actuators position. Note that to ensure the positive opening, the actuator should be moved at least to the indicated travel (➡).

Code	OF máx. ① (kgf)	PF mín. ② (kgf)
MK2A	0,90	3,50
MK2F	0,90	3,50
MK2H	0,31	1,50
MK2L	0,50	2,00

Accessory

MK23 - Terminal cover (to be screw fixed in the bottom side of the base)

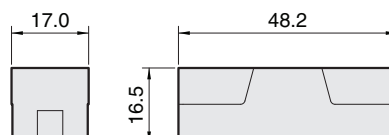

INSTALLATION INSTRUCTIONS

1- Positive Opening

- The symbol  (IEC 60947-5-1 Annex K) identifies a positive opening in the normally closed contacts (NC).
- A switch has positive opening when all NC contact elements can be certainly led to open position. There is no elastic connection between the mobile contact and the actuator element where the force is applied.
- With the positive opening system, even with a internal malfunction of the switch, for example welding of contacts, the opening of the NC contact and "shutdown" of the circuit controlled by this switch is guaranteed, provided the "union" strength between the mobile contact and NC contact, does not exceed 10 N (according to item K8.3.7 of IEC 60947-5-1 standard).
- To ensure positive opening, the external actuator element will provide a force on the actuator's switch greater than the necessary force to operate the product in normal use conditions. This force will be applied in the same position of OP.
- The connections of security circuits should be made only in NC contact and the auxiliary connections in NO contact.

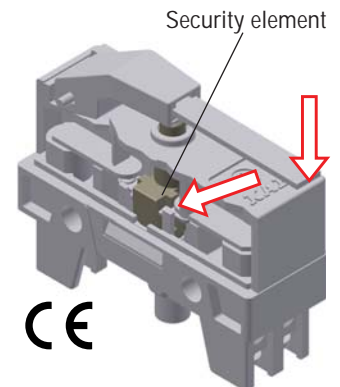

Switch operated and with the security element activated

2- Electrical Connections

2.1- Cable's cross section (flexible cables)

- minimum: 1 x 0,5 mm²
- maximum: 1 x 2,5 mm²
- Fixing torque: 0,2 until 0,3 Nm

2.2- Circuitry (with protection fuse)

- Circuit: IEC 60947-5-1 form Y+Y
- Marking: IEC 60947-1

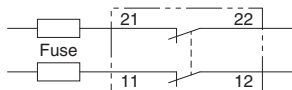

2.3- Switch MK with Mk23 terminal cover

- We recommend using Mk23 to protect people against access to dangerous parts.
- The MK23 is fixed to MK by self-tapping screw.
- Fixing torque: 0,2 until 0,3 Nm
- Option 4 outputs for cables (see figure, identification **1** until **4**). To create an output, it break with a screwdriver the membrane that cover the chosen output.
- Outputs **1** and **4**: arrows **a** and **b** indicate the locations and the appropriate position of the screwdriver to start up breaking the side membrane.
- Outputs **2** and **3**: position the screwdriver in the contours of the output and break the membrane.

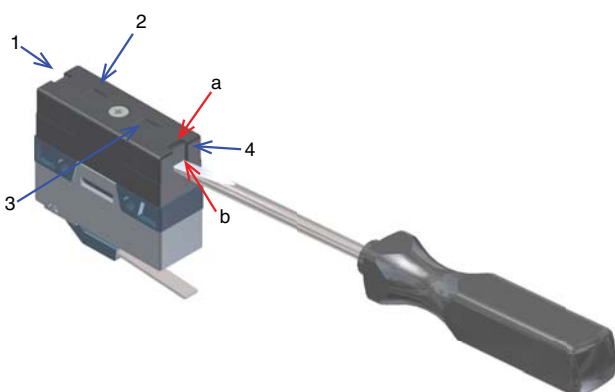

2.4- Cables Fixing

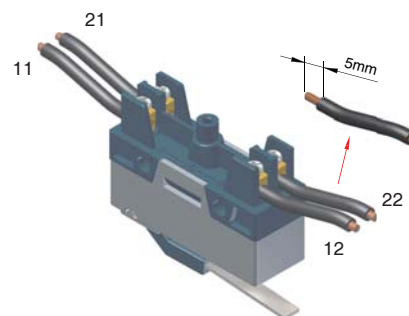

2.5- Short-circuit protective device

- 10A fuse type gG connected in series with the security circuit.

3- Housing Fixing

- Use M4 screws with flat washer.
- Fixing torque: 0,4 until 0,7Nm



4- Additional Cares

- Avoid environments where:
 - . temperature changes cause condensation.
 - . occur excessive vibration and shock and may damage the proper functioning of the switch.
 - . there is explosive or inflammable gas.
- To install the product, attempt to the specified limits to ensure a correct performance.
- Positive Opening  : attention to the values specified in the catalog to the necessary travel and force to ensure a perfect operation of positive opening system.
 - Do not use these products as a mechanical stop.
 - Do not use these products as safety or emergency stop devices or in any other application where the failure of the product could result in personal injury.

INSTALLATION INSTRUCTIONS - Continuation

⚠ WARNING

- Turn off the power to make electrical connections or before any maintenance on the switch or equipment where it is applied. **Electric shock will result in death or serious injury.**
- Installation and maintenance services for electrical equipment should be executed only by qualified personnel.
- Read these instructions carefully. Retain instructions for future reference.
- Inappropriate use of the product could result in personal injury and/or property.
- Additional informations: export@kap.com.br

5- Technical Data

- In conformity with standards	IEC 60947-5-1 / EN 60947-5-1/ IEC 60947-1/ EN60947-1/ IEC 60529/ EN 60529/ Directive 2006/95/EC
- Utilization Category	AC-15 DC-13
- Rated Operational Voltage (Ue)	240 V 125 V
- Rated Operational Current (Ie)	3 A 0,22 A
- Rated Insulation Voltage (Ui)	300 V
- Conventional Free Air Thermal Current (Ith)	10 A
- Rated Impulse Withstand Voltage (Uimp)	1500 A
- Rated Frequency	50/60 Hz
- Contact Resistance	50 mΩ maximum initial (at 1 A, 5 Vdc)
- Rated Conditional Short-circuit current	100 A
- Degree of Protection	IP20 (IEC 60529) with MK23 terminal cover assembled Equipment Protection: without protection against ingress of water and protection against access to hazardous parts ingress of solid objects up to ø12,5mm People Protection: protection against accidental touch by persons fingers +85°C maximum
- Ambient Temperature	1.000.000 cycles until 90 cycles/min max.
- Mechanical Durability	10.000 cycles until 6 cycles/min max.
- Electrical Durability	0,8 mm/s minimum until 1 m/s maximum (at pin plunger)
- Operating Speed	2 (IEC 60947-1)
- Pollution Degree	not applicable (IEC 60947-1)
- Electromagnetic Compatibility (EMC)	- Immunity: equipment not incorporating electronic circuits - Emission: electromagnetic disturbances can only be generated by equipment during occasional switching operations and the duration of the disturbances is of the order of milliseconds
- Material Housing	Glass-reinforced polymer

Subject to change without prior notice

6- Operation Recommendations

The correct way to operate the switch may affect significantly their durability. Check below some examples of actuators and their directions of operation.

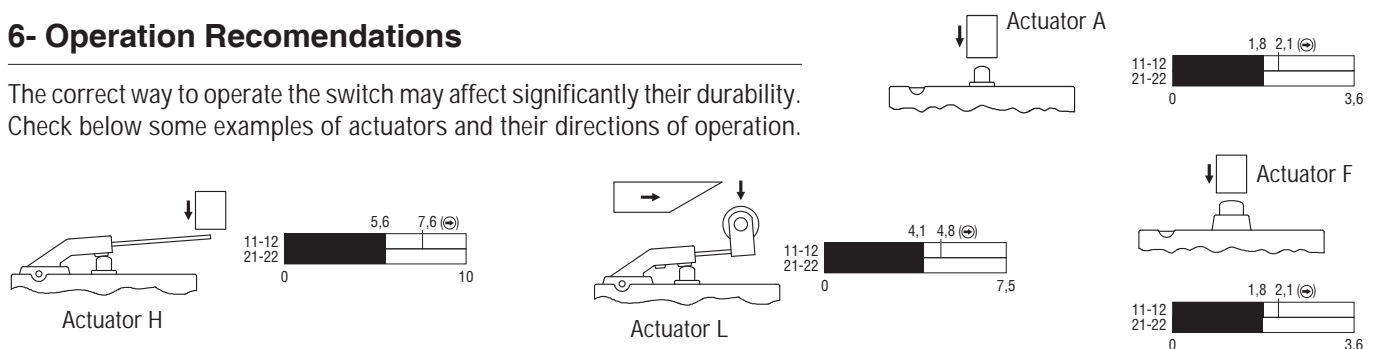

7- Travels

Terminology:

- OF..... Operation force
- PF..... Positive opening force
- PT..... Pre travel
- FP..... Free position
- OP..... Operating position
- PP.....Positive opening travel
- OT..... Overtravel

