

# KP M3 Series

## Basic Switch

- Changeover circuit with rating 16A
- Long life snap action contacts mechanism
- Self-cleaning contact action
- Variety of actuators
- Screw, front screw or quick connect (faston) terminals
- Basic dimensions according to DIN 41635 form E
- In conformity with Low Voltage Directive 2014/35/EU
- IEC 61058-1 approved component



Product  
CE

Circuitry  
(IEC 60947-5-1)

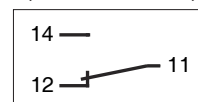

Form C (NO+NC)

## Specifications

Maximum Rated Voltage	250 V~ 50/60 Hz
Maximum Rated Current	16(3) A (16 A resistive load or 3 A motor load power factor not less than 0,6)
Ambient Temperature	T85 (0 °C up to +85 °C; CE ); T120 (0 °C up to +120 °C)
Mechanical Life Expectancy	1E6 (1.000.000 cycles) at 90 cycles/min maximum
Electrical Life Expectancy	5E4 (50.000 cycles) at 10 cycles/min maximum
Degree of Protection	IP40 (M3X: IP62 assembled on panel) (IEC 61058-1)
Protection Against Electric Shock	Class 0 - protection against electric shock relies upon basic insulation
Pollution Degree	2
Resistance to Ignitability by the Glow Wire Temperature	750 °C (flammability class UL 94 V-0)
Rated Impulse Withstand Voltage	1,5 kV
Contact Resistance	50 mΩ maximum initial (at 1 A 5 Vdc)
Operating Speed	0,05 mm/sec minimum to 1m/sec maximum (at pin plunger)
Materials	Enclosure: Thermoplastic Polyamide V-0
	Pin Plunger: Thermoplastic Polyamide V-0
	Moving Blade: Beryllium copper
	Contacts: Silver alloy
	Actuators: Lever actuator: Lever: Stainless steel
	Roller: Thermoplastic Polyamide
	Plunger actuator: Plunger: Nickel plated brass
	Roller: Zinc plated steel

Subject to change without prior notice

## Dimensions

Dimensions in mm

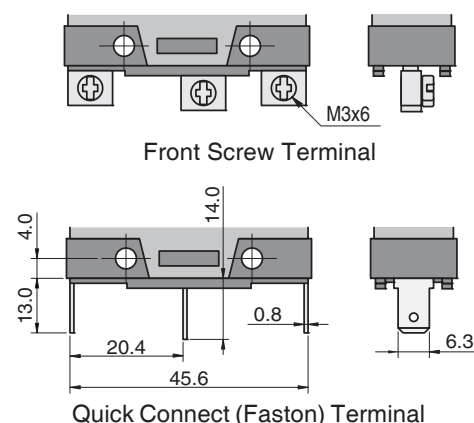
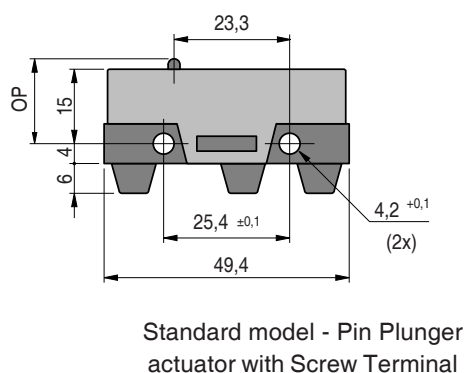

**KP COMPONENTES ELÉTRICOS Ltda.**

## Actuators

Dimensions in mm

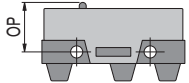

**M3A - Pin Plunger**

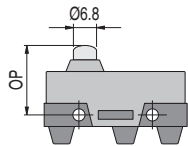

**M3F - Short Plunger**

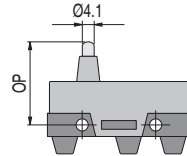

**M3D - Plunger**

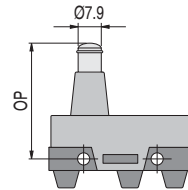

**M3B - Long Plunger**

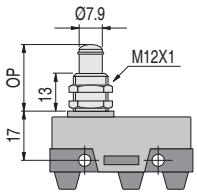

**M3C - Panel Mount Plunger**

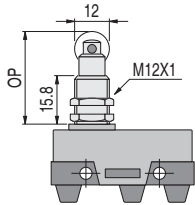

**M3S1 - Panel Mount Roller Plunger**

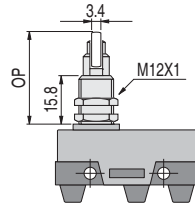

**M3S2 - Panel Mount Cross Roller Plunger**

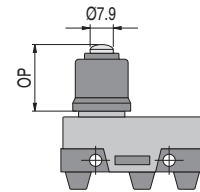

**M3X - Panel Mount Protected Plunger**

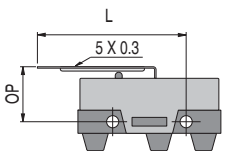

**M3E - Leaf Spring**

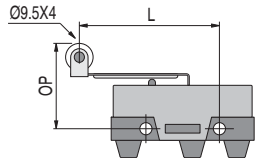

**M3R - Roller Leaf Spring**

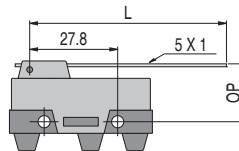

**M3G - Long Hinge Lever**  
**M3H - Long Hinge Lever**

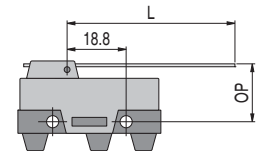

**M3M - Long Hinge Lever with reverse action**

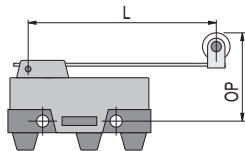

**M3J - Roller Long Hinge Lever**

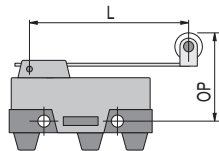

**M3K - Roller Hinge Lever**

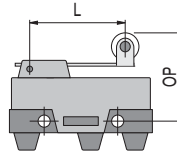

**M3L - Roller Short Hinge Lever**

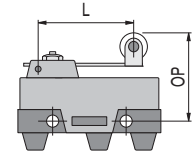

**M3L21 - Roller Hinge Lever with adjustable Operating Position**

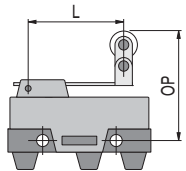

**M3Q - One-way Roller Hinge Lever**

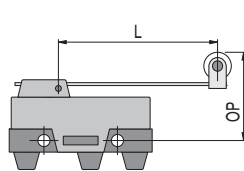

**M3N - Roller Long Hinge Lever with reverse action**

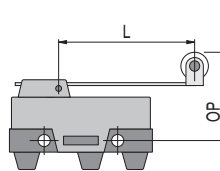

**M3O - Roller Hinge Lever with reverse action**

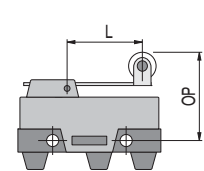

**M3P - Roller Short Hinge Lever with reverse action**

Subject to change without prior notice

## Accessory

**M33 - Terminal cover (to be screw fixed in the bottom side of the base )**

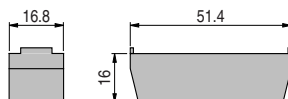

## Ordering Information

**M 3 L 9**

Ambient Temperature	
T85= (0 °C ... +85 °C)	= M3    €€
T120 (0 °C ... +120 °C)	= M31

Terminals	
Screw	= (none)
Front Screw	= 9
Quick Connect (Faston)	= F

Actuator	
Pin plunger (standard model)	= A
Short Plunger	= F
Plunger	= D
Long Plunger	= B
Panel Mount Plunger	= C
Panel Mount Roller Plunger	= S1
Panel Mount Cross Roller Plunger	= S2
Panel Mount Protected Plunger	= X
Leaf Spring	= E
Roller Leaf Spring	= R
Long Hinge Lever	= H
Long Hinge Lever (low force)	= G
Reverse Action Long Hinge Lever	= M
Roller Long Hinge Lever	= J
Reverse Action Roller Long Hinge Lever	= N
Roller Hinge Lever	= K
Reverse Action Roller Hinge Lever	= O
Roller Short Hinge Lever	= L
Reverse Action Roller Short Hinge Lever	= P
Roller Short Hinge Lever with Adjustable Operating Position	= L21
One-way Roller Short Hinge Lever	= Q

Subject to change without prior notice

## Special Applications

Even though the products presented in this catalog for regular commercial use, we are able to develop "personalized" models for special applications. Contact us. Examples:

- Enclosure in others materials
- Gold plated contacts
- Special lengths, materials and forms for the actuators

### Characteristics

**Terminology:** OF .... Operating Force  
 OP ... Operating Position  
 PT .... Pretravel  
 FP .... Free Position  
 DT ... Differential Travel  
 OT ... Overtravel  
 L ..... Actuator Length

Code	OF máx. (gf)	OP (mm)	FP máx (mm)	PT máx. (mm)	DT máx (mm)	OT mín (mm)	L (mm)
M3A / M31A	400	16,0±0,4	-	0,7	0,15	0,4	-
M3F / M31F	400	21,2±0,6	-	0,7	0,15	1,4	-
M3D / M31D	400	28,2±0,6	-	0,7	0,15	2,2	-
M3B / M31B	400	38,1±0,6	-	0,7	0,15	4,2	*
M3C / M31C	400	21,1±0,6	-	0,7	0,15	4,2	-
M3S1 / M31S1	400	32,6±0,8	-	0,7	0,15	3,7	-
M3S2 / M31S2	400	32,6±0,8	-	0,7	0,15	3,7	-
M3X / M31X	500	26,6±0,6	-	1,3	0,15	4,2	-
M3E / M31E	160	17,4±1,2	23,0	-	0,8	0,7	48,8±0,8
M3R / M31R	170	28,7±1,8	34,0	-	0,8	0,7	45,5±1,0
M3H / M31H	46	19,0±3,0	29,0	-	2,1	1,8	63,5±0,4
M3G / M31G	32	19,0±3,0	-	8,5	2,1	1,8	63,5±0,4
M3M / M31M	145	19,0±3,8	27,5	-	2,2	4,1	54,5±0,6
M3J / M31J	33	30,2±3,5	-	8,1	2,0	3,2	60,5±0,5
M3N / M31N	130	30,2±3,6	38,5	-	2,2	3,9	51,5±0,6
M3K / M31K	58	30,2±2,8	38,0	-	1,6	2,5	48,5±0,5
M3O / M31O	180	30,2±2,7	36,5	-	1,6	3,1	39,5±0,6
M3L / M31L	105	30,2±1,8	34,0	-	0,9	0,7	26,6±0,5
M3P / M31P	460	30,2±1,6	34,0	-	0,7	0,9	17,6±0,6
M3L21 / M31L21	105	adjustable	34,0	-	0,9	-	26,6±0,5
M3Q/ M31Q	105	41,3±2,0	46,0	-	0,9	0,7	26,4±0,5

Subject to change without prior notice

## INSTALLATION INSTRUCTIONS

### ⚠ WARNING

- Turn off the power to make electrical connections or before any maintenance on the switch or equipment where it is applied.
- Electric shock will result in death or serious injury.**
- Do not use these products as safety or emergency stop devices or in any other application where the failure of the product could result in personal injury.
- Installation and maintenance services for electrical equipment should be executed only by qualified personnel.
- Read these instructions carefully. Retain instructions for future reference.
- Inappropriate use of the product could result in personal injury and/or property.
- To install the product, attempt to the specified limits to ensure a correct performance.
- Do not use these products as a mechanical stop.
- Avoid environments where:
  - temperature changes in cause condensation
  - occur excessive vibration and shock and may damage the proper functioning of the switch
  - there is explosive or inflammable gas.
- Additional informations: sak@kap.com.br

## 1- Electrical Connections

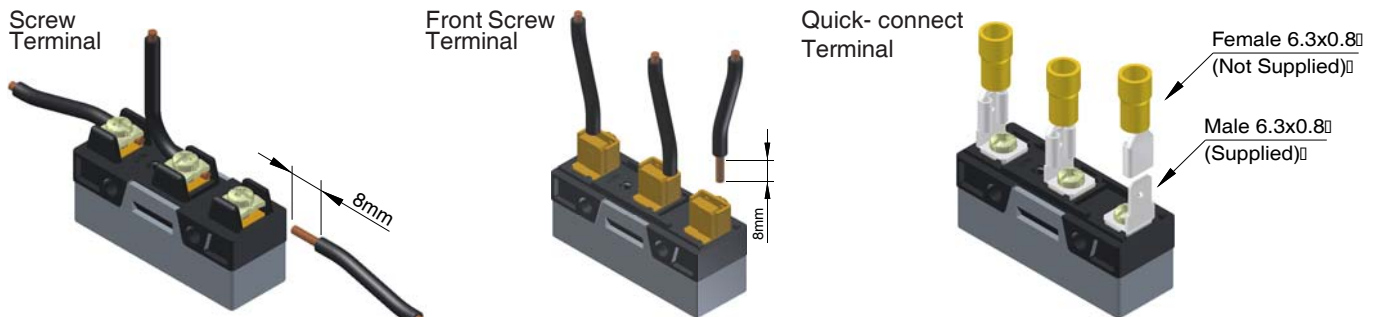

When installing cables:

- Use appropriate driver for the applied load (IEC 61058-1).
- Do not exceed the specified torque.
- Test the fixation drivers before applying the load.
- Front screw terminal: install the cables fixing them on the largest surface of the terminal.

### 1.1- Cables - IEC 61058-1 (flexible cables)

- minimum: 1 x 1 mm<sup>2</sup>
- maximum: 1 x 2,5mm<sup>2</sup>

### 1.2- Cables - Fixing Torque

Terminal (all models)	Thread	Torque (N.m)	Torque (lb.in)
	M3,5	0.5...0.8	4.4...7.1

### 1.3- Circuitry (with protection fuse)

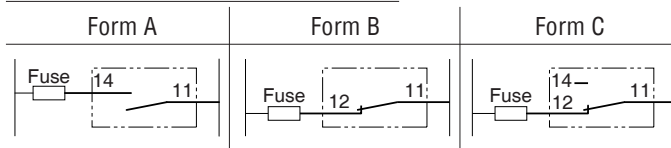

- Marking: IEC 60947-1

### 1.4- Short-circuit protective device

- 10 A 500 V fuse, type gG, connected in series with the security circuit.

## 2- Housing Fixing

- Use M4 screws with flat washer.
- Fixing Torque: 0,4...0,7 Nm / 3.5...6.2 lb.in

- Use female connectors according to IEC 61058-1, appropriated to the load and the conductor specified.
- When connecting female connectors, push it up to stop the male terminal.
- Use appropriate tool to crimp the conductor to the female terminal.

### 1.5- Switch M3 with M33 terminal cover

- We recommend using M33 to protect people against access to dangerous parts.
- The M33 is fixed to M3 by self-tapping screw.
- Fixing torque: 0,2 until 0,5 Nm
- Triple cables output options: the first one is indicated by screwdriver and the others by arrows (see figure below).
- To create the cable outline, use screw driver to break the membrane of the chosen output.

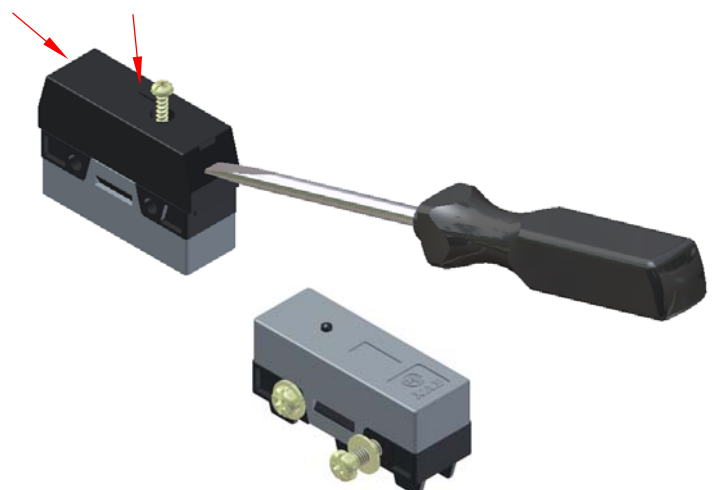

Subject to change without prior notice



# M3 Series

# Basic Switch

## INSTALLATION INSTRUCTIONS - Continuation

### 3- Technical Data

- In conformity with standards IEC 61058-1 / Directive 2014/35/EU
- Rated Voltage 250 V; 50/60 Hz
- Rated Current 16(3) A; switch for a.c. only; circuit disconnection: full disconnection
- Impulse Withstand Voltage 1.5 kV
- Insulation Resistance 100 MΩ minimum (at 500 Vcc)
- Dielectric Strength 1.5 kV minimum (at 50/60 Hz / 60 s)
- Contact Resistance 50 mΩ maximum initial (at 1 A 5 Vdc)
- Ambient Temperature +85°C maximum
- Protection Against Electric Shock Class 0 - protection against electric shock relies upon basic insulation
- Mechanical Durability 1E6 (1.000.000) cycles until 90 cycles/min max.
- Electrical Durability 5E4 (50.000) cycles until 10 cycles/min max.
- Degree of Protection IP40 (all actuators except X actuator): protected against solid foreign objects of 1,0 mm diameter and greater (IP4X); non-protected against ingress of water (IPX0)  
IP62 (X actuator): dust-tight (IP6X); protected against vertically falling water drops when enclosure tilted up to 15° (IPX2)
- Pollution Degree (IEC 61058-1) Degree 2: only non-conductive pollution occurs except that occasionally a temporary conductivity caused by condensation is to be expected
- Electromagnetic Compatibility (EMC) (IEC 61058-1) Not applicable
  - Immunity: mechanical switches without electronic circuits are considered not to be affected by electromagnetic disturbances
  - Emission: mechanical switches without electronic circuits are considered not to generate continuous electromagnetic disturbances
- Material Housing Resistance to ignitability by the glow wire temperature: 750°C
- Operating Speed 0,05 mm/s minimum until 1 m/s maximum (at pin plunger)

### 4- Operation Recommendations

The correct way to operate the switch may affect significantly their durability. Check below some examples of actuators and their directions of operation.

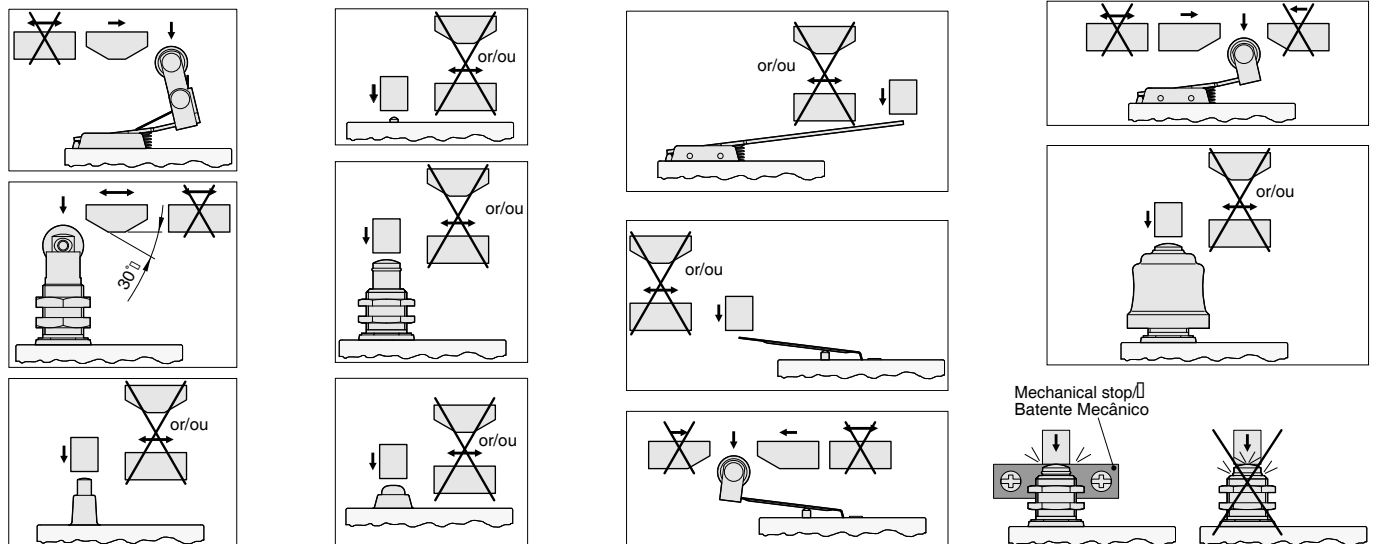

### 5- Travels <sup>①</sup>

#### Terminology:

- OF..... Operation force
- RF.....Release force
- DT..... Differential travel
- PT..... Pre travel
- FP..... Free position
- OP..... Operating position
- OT..... Overtravel

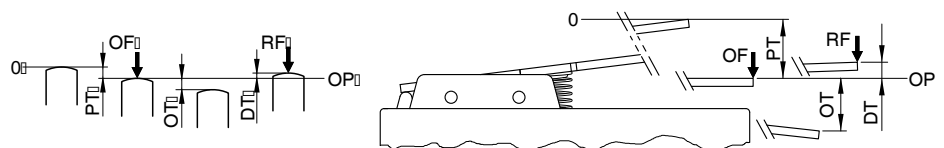

① Forces and courses values vary for each model and can be obtained from commercial catalog or [www.kap.com.br](http://www.kap.com.br).



KAP COMPONENTES ELÉTRICOS Ltda.